



Efficiency Within Easy Reach.





FAMA Round Shelf – efficiency in the round

The FAMA Round Shelf gives you fast, direct access to medicines which are frequently dispensed. The combination of the FAMA Round Shelf and the FAMA Shelving System 300 and 500 provides sophisticated storage of medicine packages arranged by their selling speed. The results are greatly reduced picking times, faster service and enhanced productivity.

Benefits:

- Direct access from the workplace – without having to go far
- Very good visibility ensures that packs are quickly found
- Stocking and dispensing can be done simultaneously from different sides
- Simple and comfortable restocking through magnetic mechanism (patent pending)
- Maintaining the 'first-in, first-out' principle through stocking of sloping channels from the back



Simple operation by rotation of shelves



Fast picking of packs; the next pack quickly slides into place in the sloping channel



Easy restocking by opening a gap between storage segments, which are held together with magnets (patent pending)



Supports the 'first-in, first-out' principle as you stock sloping channels from the back



Optional label holders for fast and clear identification of items

FAMA Round Shelf 1200

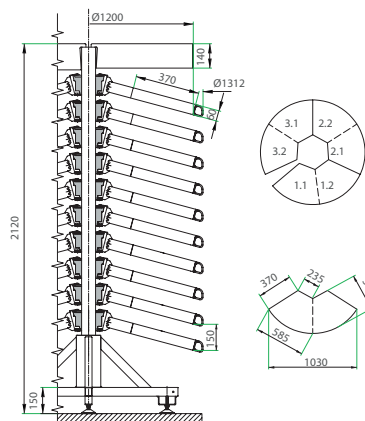

Diameter:	1200 mm (storage segments 1312 mm)
Height:	2120 mm
Footprint (base):	1.4 m ²
Storage area:	6 m ²
Capacity:	Up to 400 product lines (channels) with up to 3,400 packages
Number of shelves:	10
Depth of shelves:	370 mm

FAMA Round Shelf 1800

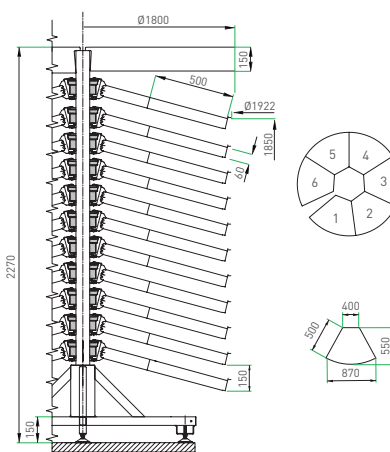

Diameter:	1800 mm (storage segments 1922 mm)
Height:	2270 mm
Footprint (base):	2.9 m ²
Storage area:	13 m ²
Capacity:	Up to 700 product lines (channels) with up to 8,000 packages
Number of shelves:	11
Depth of shelves:	500 mm



Willach Pharmacy Solutions. The right prescription for every pharmacy.

Willach is the market leader in Europe for medicine storage and dispensing equipment. With FAMA and CONSYS, Willach can provide whole system solutions for the conventional and fully automated storage of medicine packages, for any type of pharmacy, for any size of pharmacy. Willach undertakes all product development and production in Germany to assure the highest quality standards.



CONSYS robotic systems

CONSYS robotic dispensers offer a tailor-made and highly efficient automation concept for your pharmacy. Whether you want to save time or gain space, CONSYS has the right solution for every situation.

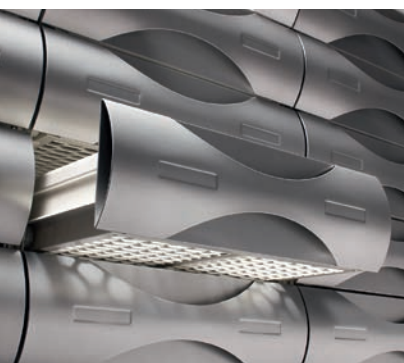

FAMA drawer systems

FAMA drawers provide fast access to packages, with good visibility, excellent space utilisation and ergonomically perfect operation. No other system offers you drawers that can store more packages within the same space.



FAMA shelving systems

FAMA shelving systems were developed as a modular system to achieve the greatest possible flexibility. They can be adapted precisely to your individual requirements, storing the items in trays, drawers or on flat shelves. Worktops can be integrated as well.



UK Sales Office:

Willach Pharmacy Solutions
Concorde House
Trinity Park, Solihull
Birmingham B37 7UQ
United Kingdom
Phone +44 (0) 1216 355 025
info.uk@willach.com
www.willach.com

German Head Office:

Gebr. Willach GmbH
Stein 2
53809 Ruppichteroth
Germany
Phone +49 (0) 2295 9208 0
Fax +49 (0) 2295 9208 499
info@willach.com
www.willach.com

WillachGroup
since 1889

